

LDE-ST/LEW-ST Data sheet

The steel structure torque wrench



Light. Robust.

- » High torque at low device weight, torque accuracy better than 3%
- » Visual, acoustic operation via digital display
- » Automatic shut-off when reaching the torque with relaxation of the reaction arm

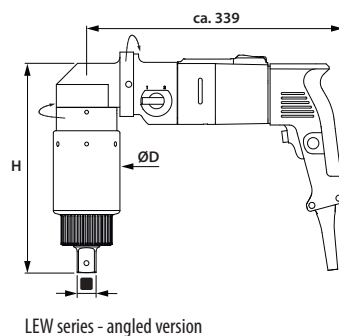
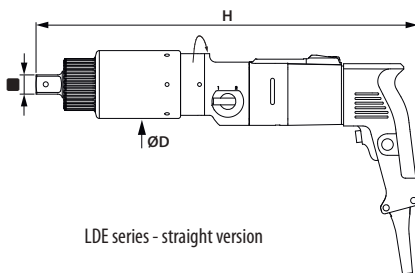

Steel Structure Torque Wrench

- LDE-/LEW-09ST; Tightening of HV-connections from M12 to M24 (10.9)
- LDE-/LEW-16ST; Tightening of HV-connections from M16 to M30 (10.9)
- LDE-/LEW-28ST; Tightening of HV-connections from M20 to M36 (10.9)

Technical Data

Type	N-m min*1/ max*2	lbf-ft min*1/ max*2	~ U/min	■	Ø D mm	H mm	kg*3
LDE - 09ST	120 - 900	90 - 670	19.0	3/4"	80	439	5.2
LDE - 16ST	300 - 2200	220 - 1620	7.0	1"	88	472	6.6
LDE - 28ST	450 - 3200	330 - 2360	6.1	1"	88	495	7.3
LEW - 09ST	120 - 900	90 - 670	19.0	3/4"	80	220	6.5
LEW - 16ST	300 - 2200	220 - 1620	7.0	1"	88	253	7.9
LEW - 28ST	450 - 3200	330 - 2360	6.1	1"	88	276	8.6

*1 Lowest torque in 2nd gear *2 Maximum torque in 1st gear *3 Without reaction arm
All rights reserved. Subject to modifications without prior notice.